

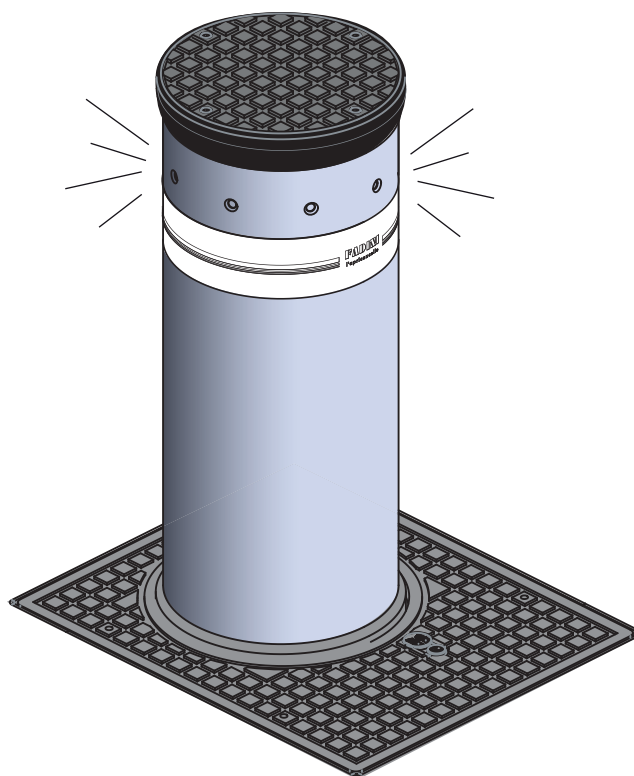

TALOS



**BOLLARD WITH RETRACTABLE CYLINDRICAL POST
OIL-HYDRAULICALLY OPERATED**



FADINI
the gate opener
made in Italy

TO ACHIEVE A PERFECT INSTALLATION OF THE TALOS BOLLARDS IT IS RECOMMENDED TO FOLLOW THE INSTRUCTIONS AND THE DRAWINGS HERE INCLUDED.

NOTE WELL: THE ENTIRE INSTALLATION IS TO BE CARRIED OUT BY QUALIFIED TECHNICIANS IN COMPLIANCE WITH THE EN 12453 - EN 12445 SAFETY NORMS, AND THE MACHINERY DIRECTIVE 2006/42/CE.

A COMPLETE ANALYSIS OF THE RISKS IS REQUIRED IN COMPLIANCE WITH THE SAFETY NORMS IN FORCE.

It is recommended to take notice of the guide to the Technical file on www.fadini.net/supporto/download



This symbol indicates that a particular attention is required on the installation phases and on running the operator. Failure to observe these indications may cause incorrect functioning of the bollard.



PRELIMINARY INFORMATION ABOUT SAFETY AND PROPER FUNCTIONING OF THE SYSTEM



Before the bollard is physically embedded into the ground, please note the following:

- 1) Installation operations, testing, analysis of the risks and future maintenance are to be executed by qualified and authorized technicians in compliance with the existing regulations (www.fadini.net/supporto/download)
- 2) This automatic system is intended to be exclusively used for the applications described in this manual, including all of the safety and command accessories, at least as required.
- 3) Any application not indicated in this manual may cause malfunctioning or damages to people and properties.
- 4) Make sure the soil is adequate to take the bollard to avoid that settling at a later stage causes problems to the system
- 5) Make sure the site is free from utilities that may interfere with it.
- 6) Make sure that electromagnetic sources are at a suitable distance from the accessories, especially from the loop detectors. The magnetic fields of other sources might affect the detections of the safety loops as well as those of the other command and safety devices of the system.
- 7) Make sure the power supply to the electric motor is 230 V (50 Hz).
- 8) **It is recommended either of the following power supply cables:**
 - cable type **BUT FLESSIBILE FG 70R 12x1,5 mm² (up to 50 m maximum): for the TALOS bollard in the standard version, without optional accessories;**
 - cable type **BUT FLESSIBILE FG 70R 12x1,5 mm² (up to 50 m maximum): for the TALOS bollard in the version fitted with two optional accessories maximum (either solenoid valve, obstacle detector or heater);**
 - cable type **BUT FLESSIBILE FG 70R 16x1,5 mm² (up to 50 m maximum): for the TALOS bollard in the version fitted with all of the three optional accessories (solenoid valve, obstacle detector and heater);**

N.W. The presence or not of the beeper on the TALOS bollard, does not affect the cable choice.
The section of the ground cable is to be chosen in compliance with the requirements of the installation site.
- 9) In case any components or accessories need replacing, use only original parts as provided by the manufacturer.
- 10) The installer shall provide the final user with information related to all of the operating commands and functions of the system, including that concerning lowering of the post in case of an emergency (manual release operation).
- 11) The installer shall inform the final user of the dangers coming from the presence of persons, especially children, in the proximity of the bollard.
- 12) The manufacturer reserves the right to change this manual without previous notice.



Meccanica Fadini is not liable for any possible damages derived from incorrect use or from any use not indicated in this manual, furthermore it is not answerable for malfunctioning caused by the use of materials or accessories not approved by the company itself.

GENERAL DESCRIPTION OF THE PRODUCT

Talos is a bollard fitted with a fully retractable post sinking flat to the ground level. It is an oil-hydraulic system, the movements of which are by an incorporated motor-pump. It is designed to securely stop traffic from an area.

The TALOS series includes a vast selection of options as indicated below, varying in height, thickness and depth of embedding (constraint) for impact resistance. (the abbreviation HRC identifies those bollards having higher ratings of resistance to crash and impact than the standard versions).

The construction features and installation procedure are the same across the entire range:

model	post thickness	stroke	crash resistance	model	post thickness	stroke	crash resistance
TALOS 9450	4	500	320.000 J	TALOS 9651	12	500	450.000 J
TALOS 9450/HRC	4	500	420.000 J	TALOS 9651/HRC	12	500	550.000 J
TALOS 9460	4	600	320.000 J	TALOS 9661	12	600	450.000 J
TALOS 9460/HRC	4	600	420.000 J	TALOS 9661/HRC	12	600	550.000 J
TALOS 9470	4	700	320.000 J	TALOS 9671	12	700	450.000 J
TALOS 9470/HRC	4	700	420.000 J	TALOS 9671/HRC	12	700	550.000 J
TALOS 9480	4	800	320.000 J	TALOS 9681	12	800	450.000 J
TALOS 9480/HRC	4	800	420.000 J	TALOS 9681/HRC	12	800	550.000 J

The retractable post is made of Fe 360 steel, 275 mm diameter, 4 mm and 12 mm thickness options, cathaphoresis treated and polyester powder coating.

A stainless steel version is available, INOX Aisi 304 satin finish, but only in the 4 mm thickness option.

In the HRC options, the post (raised) stays embedded into the casing 40 cm (constraint) deeper rather than 20 cm as with the standard versions, thus ensuring higher resistance to impact and crash.

The electronic controller Elpro S40 is to be installed externally, in a sheltered place.

A wide range of safety and control accessories make this bollard easy and safe to operate and therefore suitable to any applications, either in public or private areas.

Any TALOS can be completed with supplementary accessories, to be specified at the time of the order as required (pre-assembled and pre-wired to the internal terminal block):

- **Solenoid valve:** it allows the post to lower in case of power failure.
- **Presence sensor (pressure switch):** it prevents the post from rising in case an obstacle stays on it.
- **Beeper:** an acoustic device operating during the rising and lowering movements of the post.
- **Heating resistor:** a device used to keep Talos warm inside when the external environment is below 5 °C.

DECLARATION OF CONFORMITY:

Meccanica Fadini snc (Via Mantova, 177/A - 37053 Cerea - VR - Italy) declares under its own responsibility that TALOS is in compliance with the Directive 2006/42/EC on machinery, moreover: is to be sold and installed as a comprehensive "Automatic System", including the accessories and components as recommended by the Manufacturing Company. In observance of the current directives, any automation is to be regarded as a "machine". Therefore it is required that all the applicable safety norms are strictly complied with by installation agents, who are also required to issue a Declaration of Conformity. The manufacturing company is not liable for incorrect applications or misuse of its products that are declared to be produced in compliance with the following norms: Analysis of the risk and actions to cure them EN 12445 & EN 12453, Low Voltage Directive 2006/95 CE, Electro-magnetic Compatibility Directive 2004/108/CE. In order to certify the product the Manufacturer declares under his own responsibility the compliance with the PRODUCT regulations under the NORMS EN 13241-1.

Meccanica Fadini s.n.c.
Responsible Manager

MAIN COMPONENTS

English

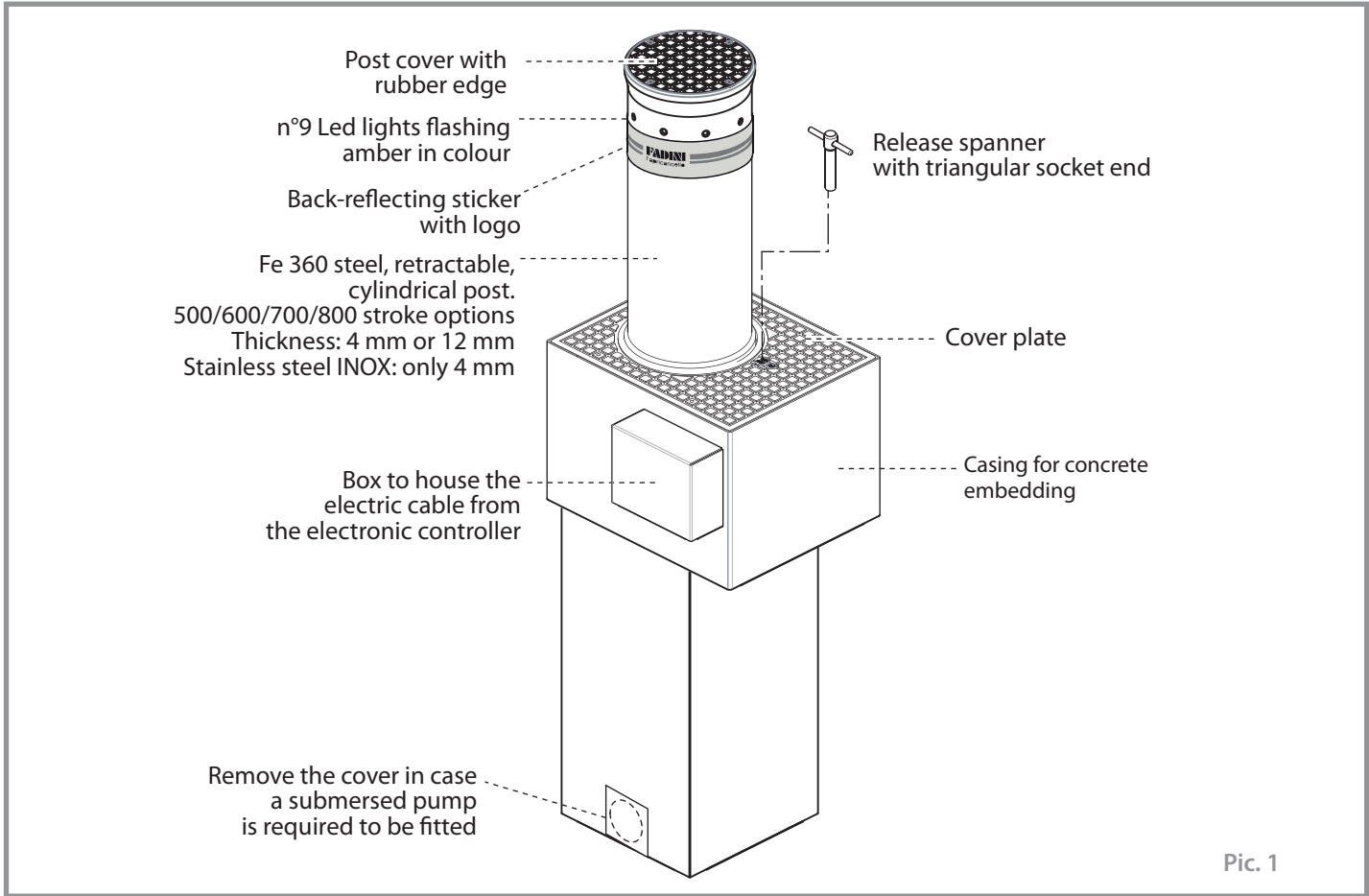

Pic. 1

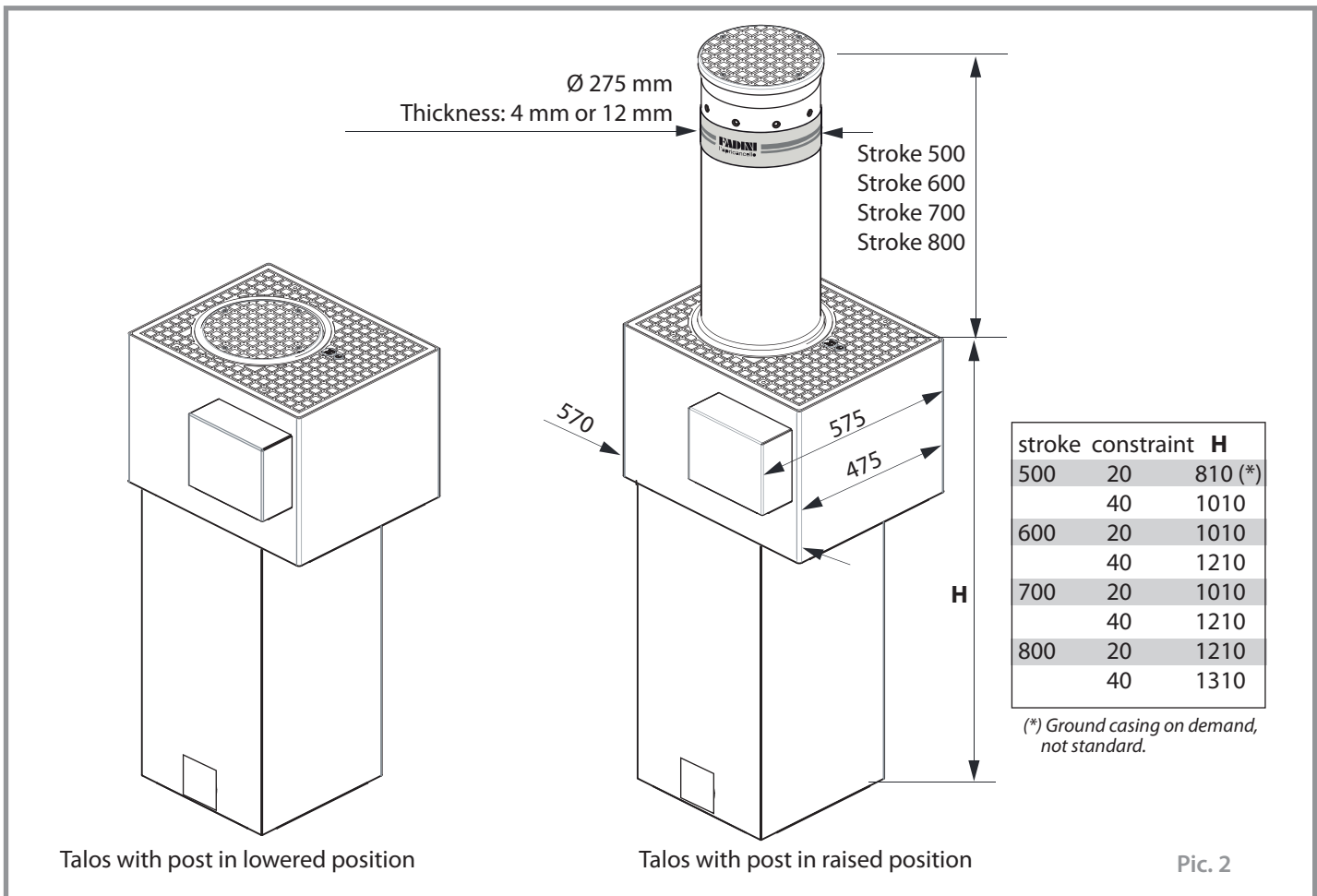

Pic. 2

COMPONENTS FOR A COMPLETE INSTALLATION

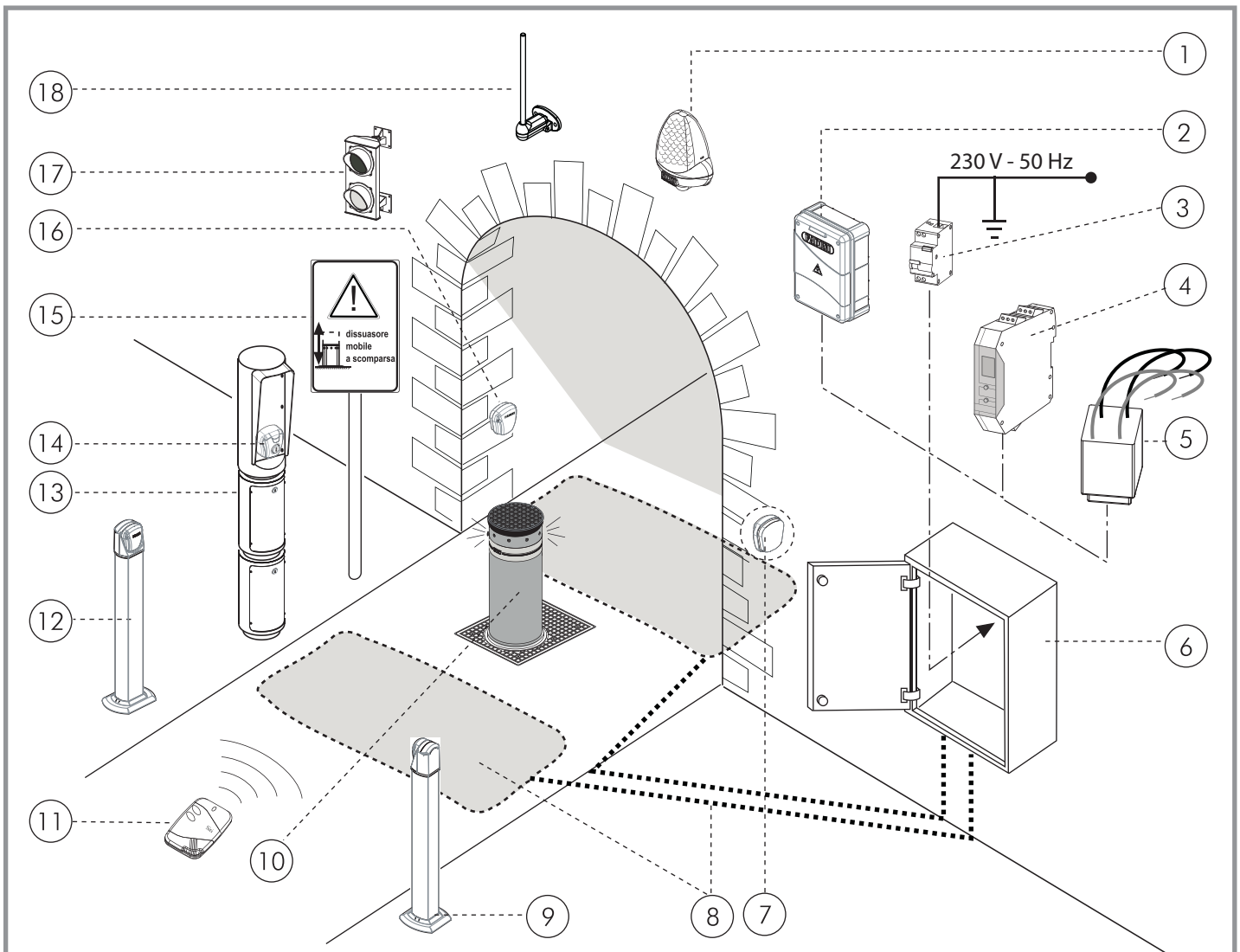

List of all the possible accessories for system operations and safety (see general catalogue).
General indicative diagram:

- 1 - Miri 4 Led flasher
- 2 - Elpro S40 electronic controller with Siti 63 radio receiver
- 3 - 0,03 A magnetic thermal circuit breaker (not in the catalogue)
- 4 - Loop detector for metallic masses, two channels
- 5 - Voltage stabilizer for single coil application (Talos with solenoid valve)
- 6 - Burglar-proof enclosure
- 7 - Fit 55 photocell receiver, recess mount
- 8 - Pre-assembled loop with power supply cable
- 9 - Post for Fit 55 photocell projector
- 10 - Oil-hydraulic bollard Talos series
- 11 - Siti 63 remote control transmitter
- 12 - Post for Fit 55 photocell receiver
- 13 - Visual 344 post to take command accessories
- 14 - Chis 37 key-switch
- 15 - Warning signal bollard in motion
- 16 - Fit 55 photocell projector, recess mount
- 17 - Double head traffic lights
- 18 - Birio A8 aerial, wall mount



**Make sure that the electric cables of all the accessories are led to the electronic controller Elpro S40 without interfering with any other utility.
Depth and diameter of the cable ducts are to comply with the principles of the good installation technique and the safety rules in force on the place of the application.**

Pic. 3

REMOVE THE BOLLARD FROM ITS CASING

English

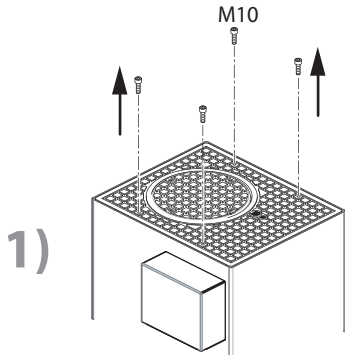

1)

Remove the M10 screws on the squared cover plate

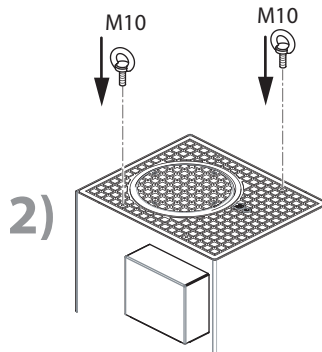

2)

Fit the two M10 lifting rings "across" the cover plate

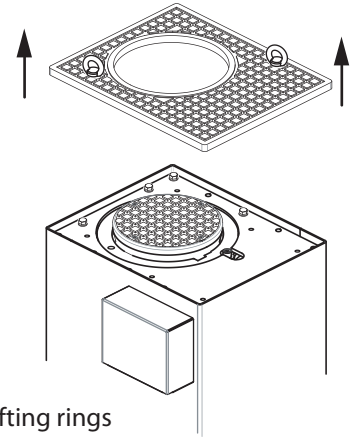

3)

Remove the inner fixing plate

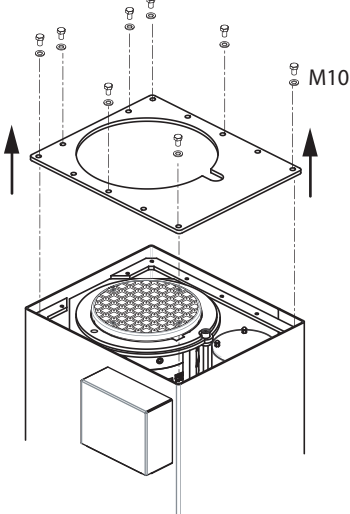

4)

Screw the two lifting rings down into the pre-holed seats

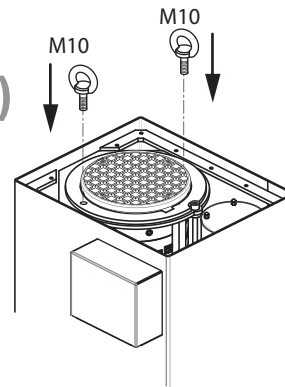

5)



NOTE WELL: make sure the ground cable is disconnected from the casing before lifting



Carefully hoist and remove the inner assembly of the bollard by a winch. Make sure the cables are not torn or cut or the inner hydraulic pipes are damaged in this phase.

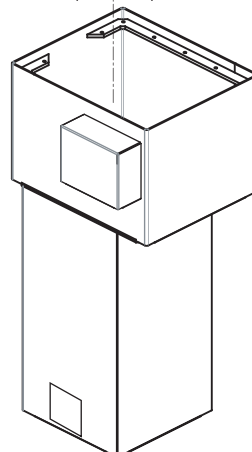
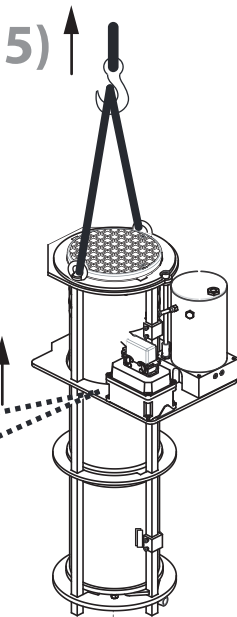
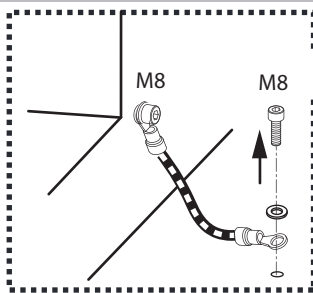

Casing to set into a concrete foundation

Pic. 4

CEMENTING THE CASING

A pit is to be dug into the ground following the dimensions as indicated in Pic.5.

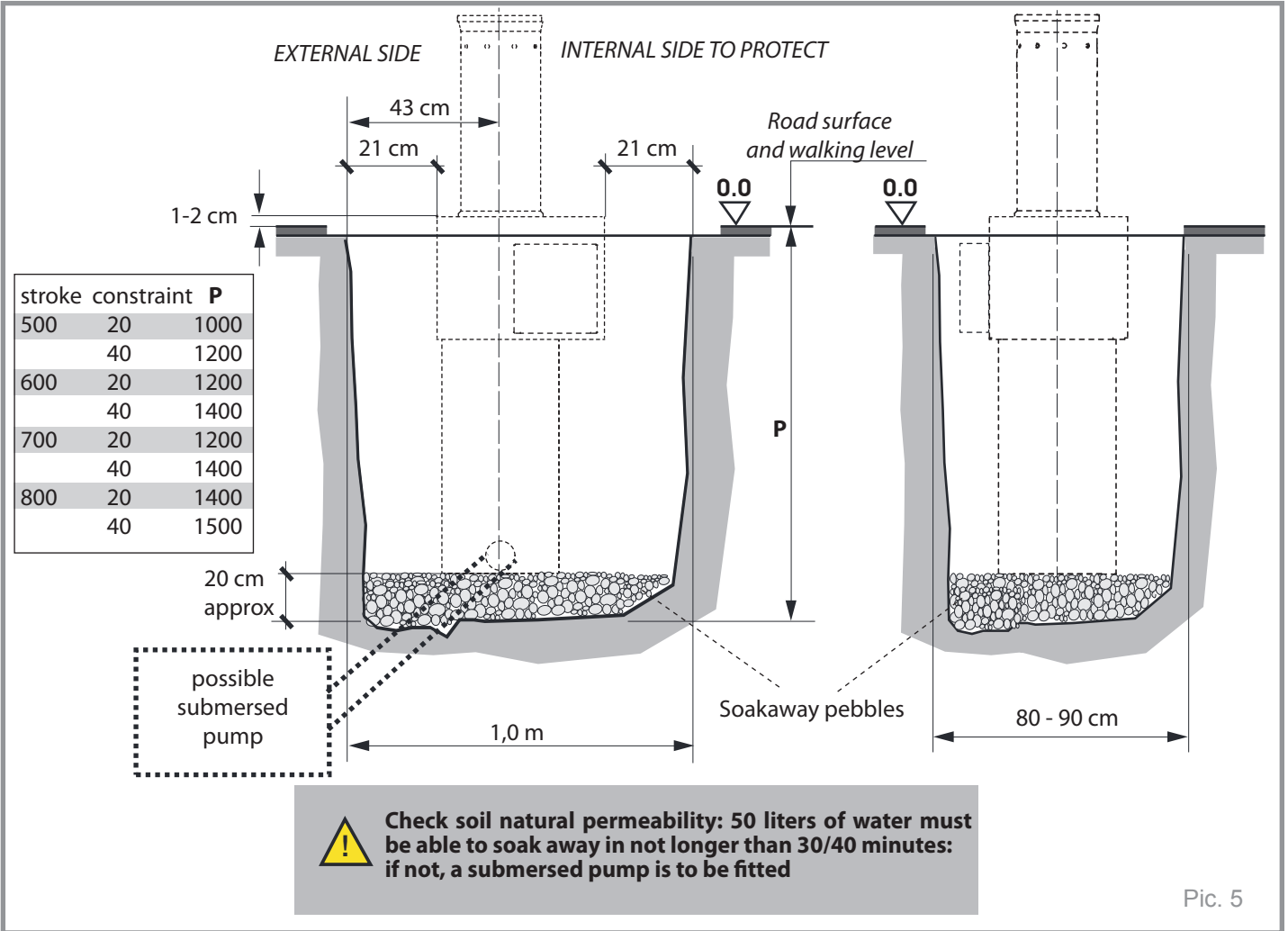

English

Lay a corrugated tube, Ø 50 mm, to lead the electric cables through it, from a junction box or directly from the electronic controller Elpro S40 (Pic.6)

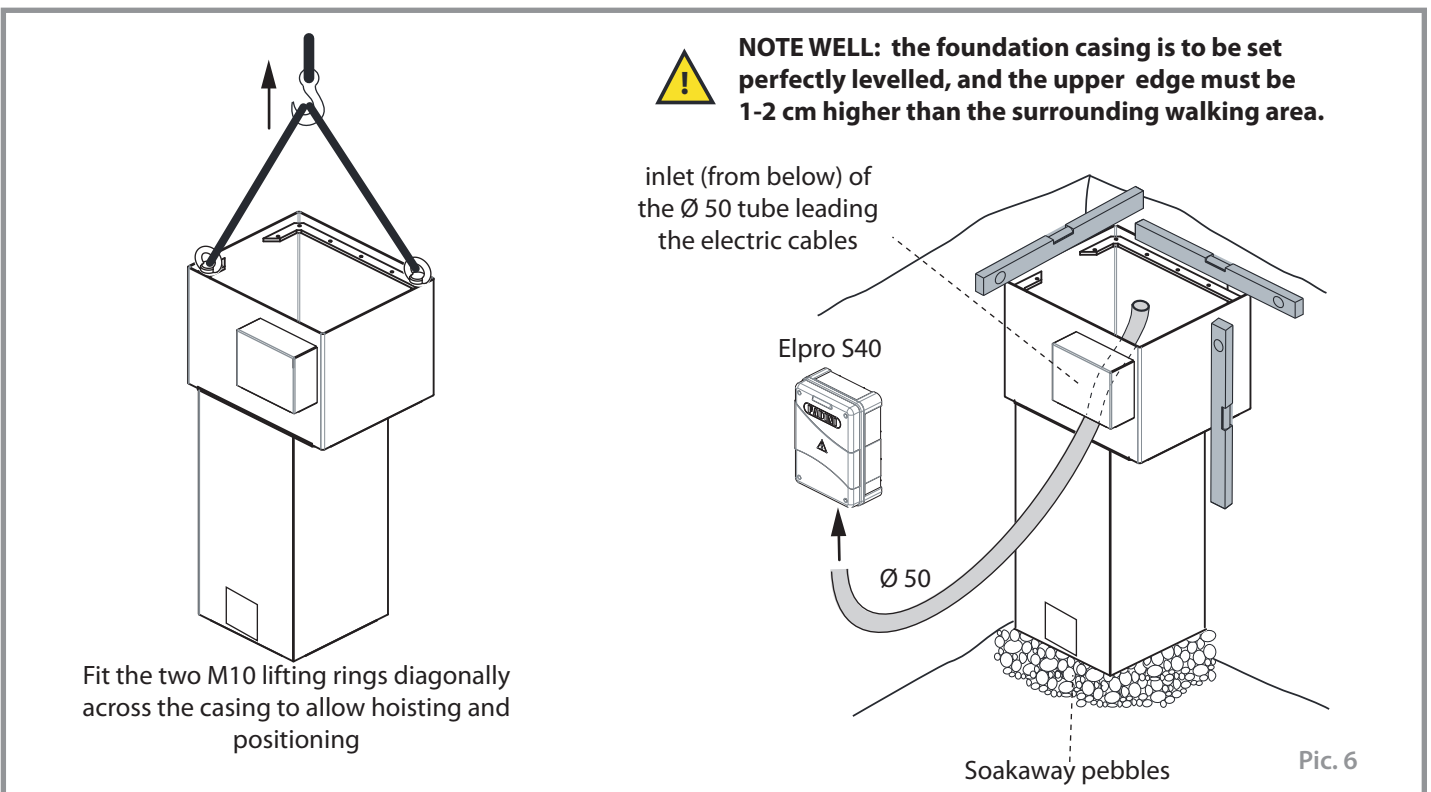



The upper level of the foundation casing is to be 1-2 cm higher than the surrounding walking surface, in order to limit the amount of water that may get inside it. Cast concrete all around the casing up to 5-10 cm from walking level. Wait all the time required for concrete to set firmly (at least 7 days) and complete the finishing of the road surface.

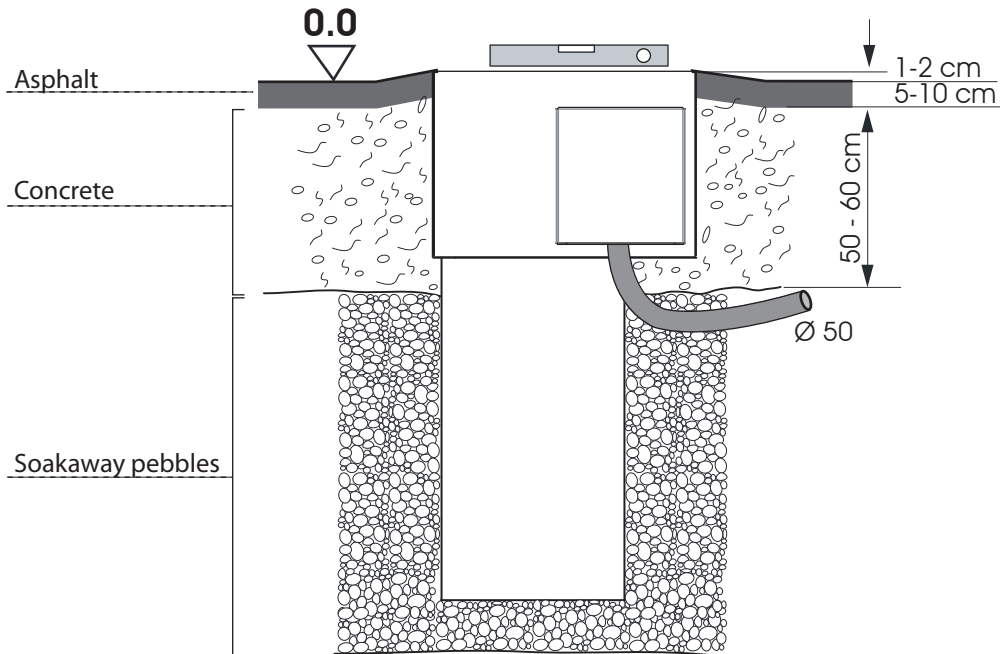

IT IS MOST IMPORTANT THAT THE CASING IS 1-2 cm HIGHER THAN AREA FINISHED LEVEL. IN NO WAY THE TALOS IS TO BECOME A WATER GATHERING BASIN. AVOID AREAS WHERE SOIL TENDS TO SAG TO PREVENT THE BOLLARD FROM BEING FLOODED. IN CASE OF SNOW, THE FLAT SURFACE OF THE COVER PLATE CAN BE EASILY CLEARED EVEN BY HEAVY MECHANICAL MEANS.

Pic. 7

INSTALLING THE BOLLARD

Once concrete has firmly set around the casing, put the inner assembly back into it. Lastly remove the lifting rings.

By a winch put carefully the inner assembly back into the casing, make sure the cables are not torn or cut or the inner hydraulic pipes are damaged in this phase



NOTE WELL: IT IS IMPORTANT THAT THE ENTIRE ASSEMBLY IS PERFECTLY FITTED BACK INTO ITS SEAT. THE PLATE, TO WHICH THE MOTOR-PUMP IS FIXED, MUST FIT WELL ONTO THE INNER SURFACE OF THE CASING. REMOVE POSSIBLE FRAGMENTS.

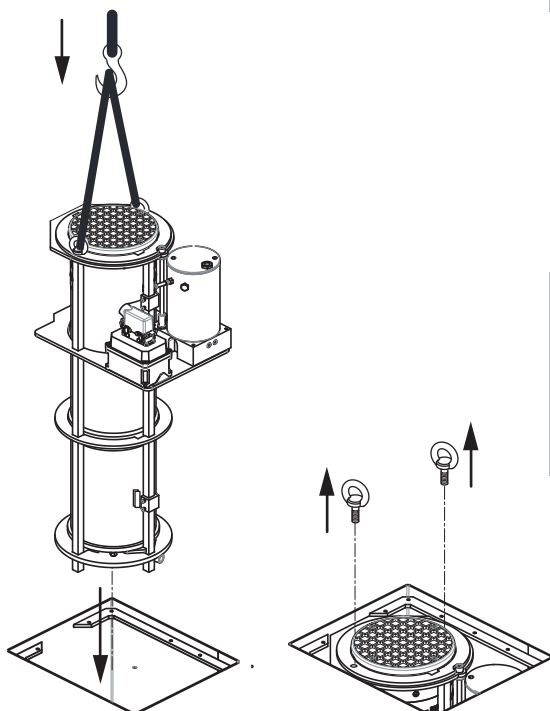

They must be on the same level



They must fit so that the dedicated groove in the casing is fitted perfectly

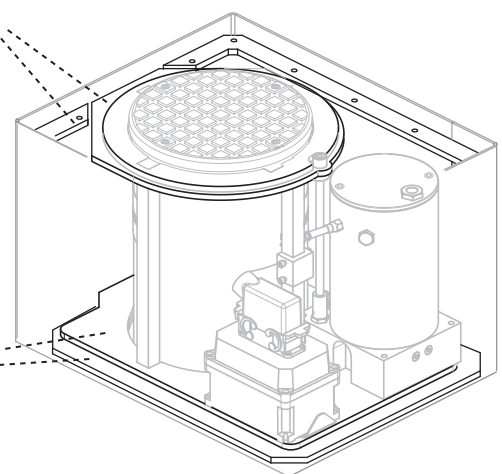

Pic. 8

ARRANGING FOR THE MAGNETIC LOOPS (OPTIONAL)

IMPORTANT: Make sure that the area near and below the ground level where the accessories are installed is clear from electromagnetic sources to prevent interference problems with the detections of the loops and with any other electronic device to control the installation. The magnetic loop is a safety device, permanently active, to detect vehicles: the bollard is prevented from rising while any vehicle is transiting on the loops.

A hole is to be dug to take the pre-assembled loops that can be provided by the company (see the instructions coming with this item to be informed about all of the possible configurations available).

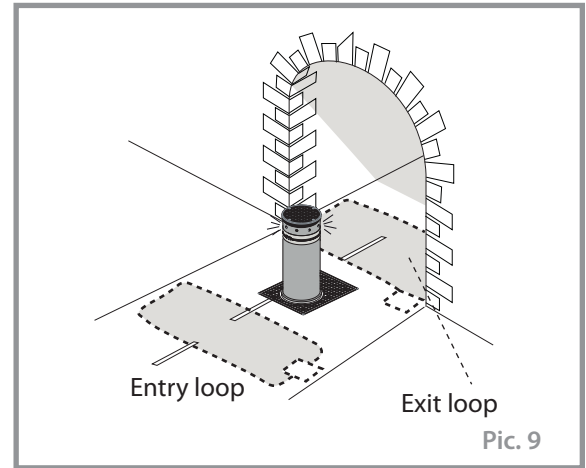

Pic. 9

English

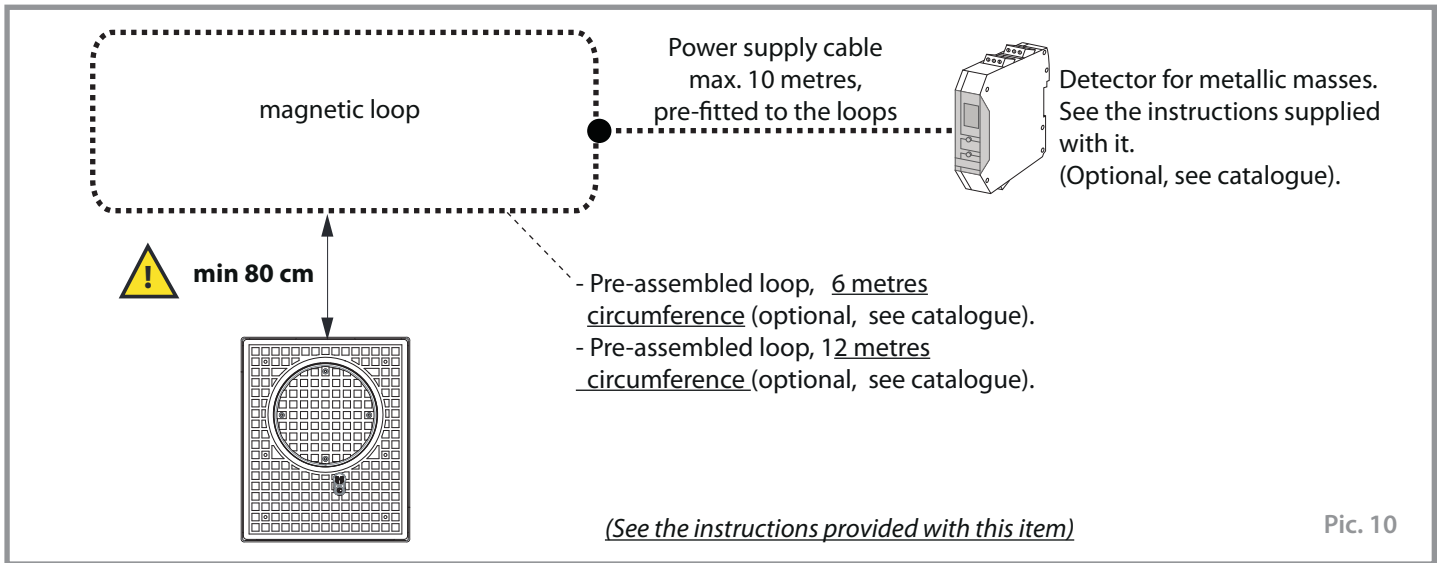

Pic. 10

INSTALLING THE PHOTOCELLS (OPTIONAL ITEM) AND OTHER COMMAND ACCESSORIES AS REQUIRED

The photocells are to be installed at a suitable minimum distance to operate properly as indicated in Pic. 11. Visual 344, with 2 or 3 elements, is a post made of metal designed to provide a support to the electronic controller Elpro S40 in those applications in the open where no other structures are available to this purpose. it is designed to also take any other control accessories, such a key-switch or a video-intercom system, as required near the installation (Pic.11)

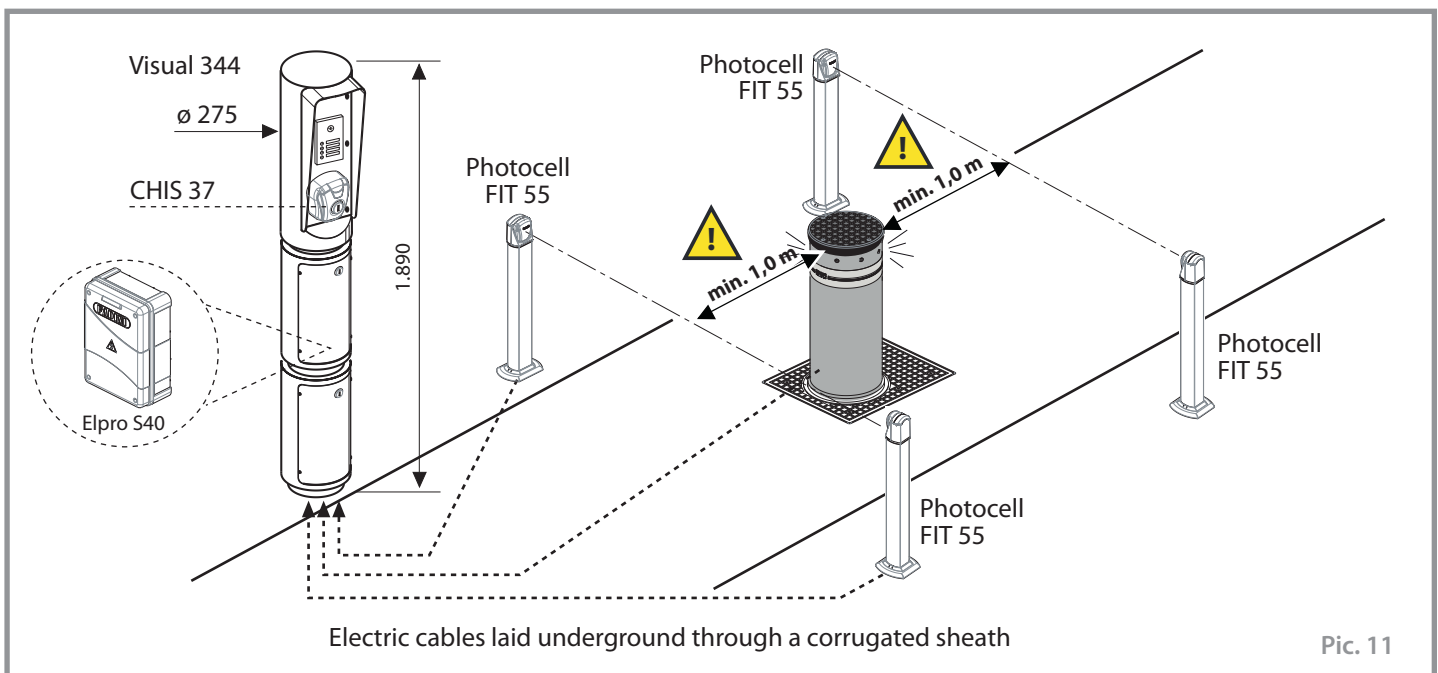

Pic. 11

ELECTRIC CONNECTIONS TO THE ELECTRONIC CONTROLLER ELPRO S40

The electronic controller Elpro S40 is to be installed in a dry and protected place to prevent unauthorized actions. Make sure that all the electric cables of the command and safety accessories are properly led to the controller (Pic.3). Through the previously laid corrugated tube pull a multicore cable, type **BUT FLESSIBILE FG 70R 12x1,5 mm²** (not supplied with the equipment, but available on request as per catalogue) or a multicore cable, type **BUT FLESSIBILE FG 70R 16x1,5 mm²** (not supplied with the equipment, but available on request as per catalogue) for the electrical connections to the Elpro S40 controller, depending on which model of TALOS is required to be installed (see page 2, point 8).

NOTE WELL: Lay a ground cable suitable to the type of installation as required either for public or private users and in compliance with the existing safety norms. A screw is provided for proper connection. For applications in public areas use a cable having a section of 16 mm².

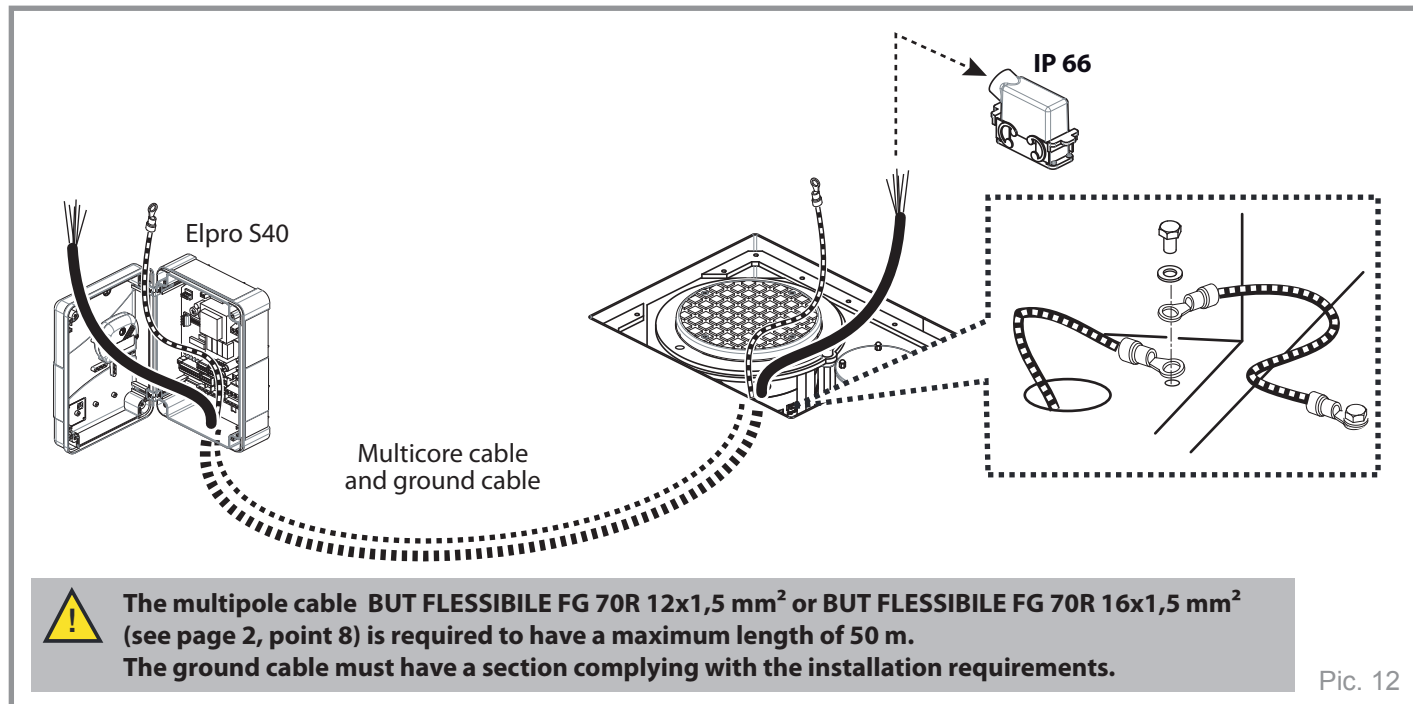

⚠ ATTENTION: before carrying on with wiring, it is recommended to identify which optional accessories TALOS is actually fitted with (pressure switch, solenoid valve, beeper or heating resistor), so to arrange the proper connections to the respective terminals in the connector.

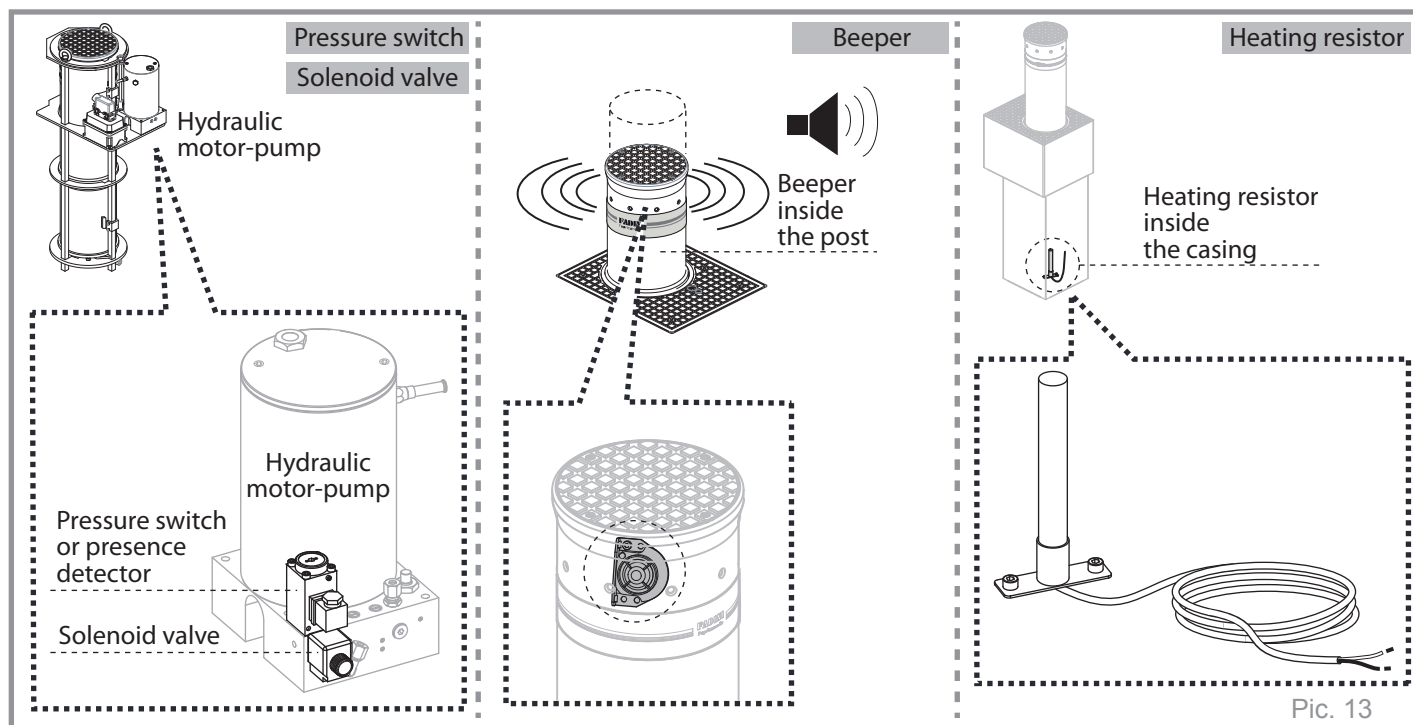

The bollard comes pre-wired (electric motor, limit switches, LEDs and possible optional items such as: beeper, solenoid valve and pressure switch). Connections are in a dedicated watertight box.

Remove the connector from the junction box and bring the connections to the respective terminals by means of a multicore cable (not supplied with the equipment).

Connections to the terminals in the Elpro S40 controller



(see the instructions enclosed with the item)

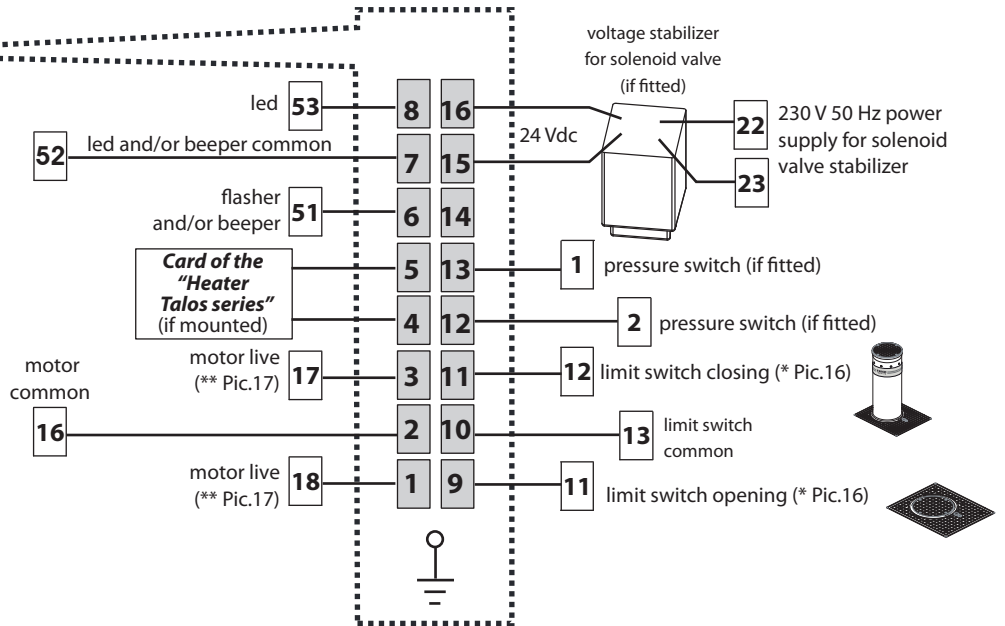
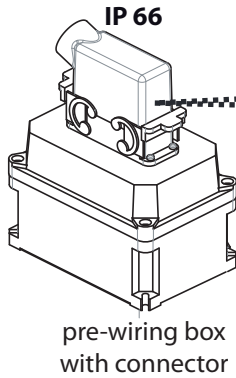

ATTENTION: A 30 μ F capacitor is pre-wired inside the junction box. For the Talos option 4 mm thickness (fe steel and Inox/stainless steel) do NOT connect any more capacitors to the terminals A and B of the Elpro S40 controller unless required to achieve a good performance of the bollard. For the Talos option 12 mm thickness a 20 μ F capacitor is required to be added to the terminals A and B of Elpro S40



ATTENTION: TIGHTEN THE CABLE GLAND VERY HARD BEFORE FITTING BACK THE CONNECTOR, OTHERWISE GRADE OF PROTECTION FROM SEEPAGE MAY BE AFFECTED

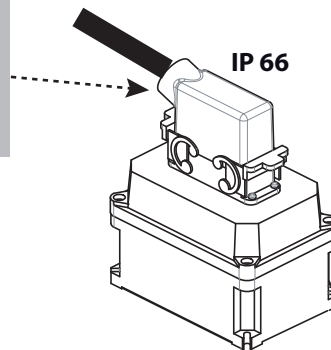

Pic. 14

FIRST RUNNING TEST

ATTENTION: supply the system with power only when wiring is completed

Once the bollard and all of the the safety (make sure that all the NC contacts in the Elpro S40 controller are actually closed) and command accessories are finally installed, the respective connections to Elpro S40 done and the risk analysis completed, the first running test can be carried out.

If a remote control is available, once satisfied it has been properly match encoded with the radio receiver following the instructions provided with it, pulse once for the post to rise.

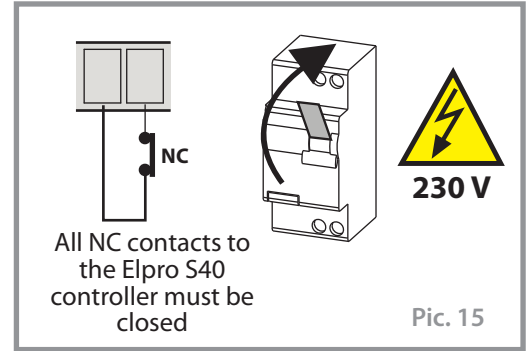

(* **Check the electrical connections to the limit switches; then, once the electric power is supplied, check the status of the LEDs first of all as follows: with the post in down position the L8 LED must be OFF, while L9 must be ON; if not, swap the connections to terminals 11 and 12 in Elpro S40.**

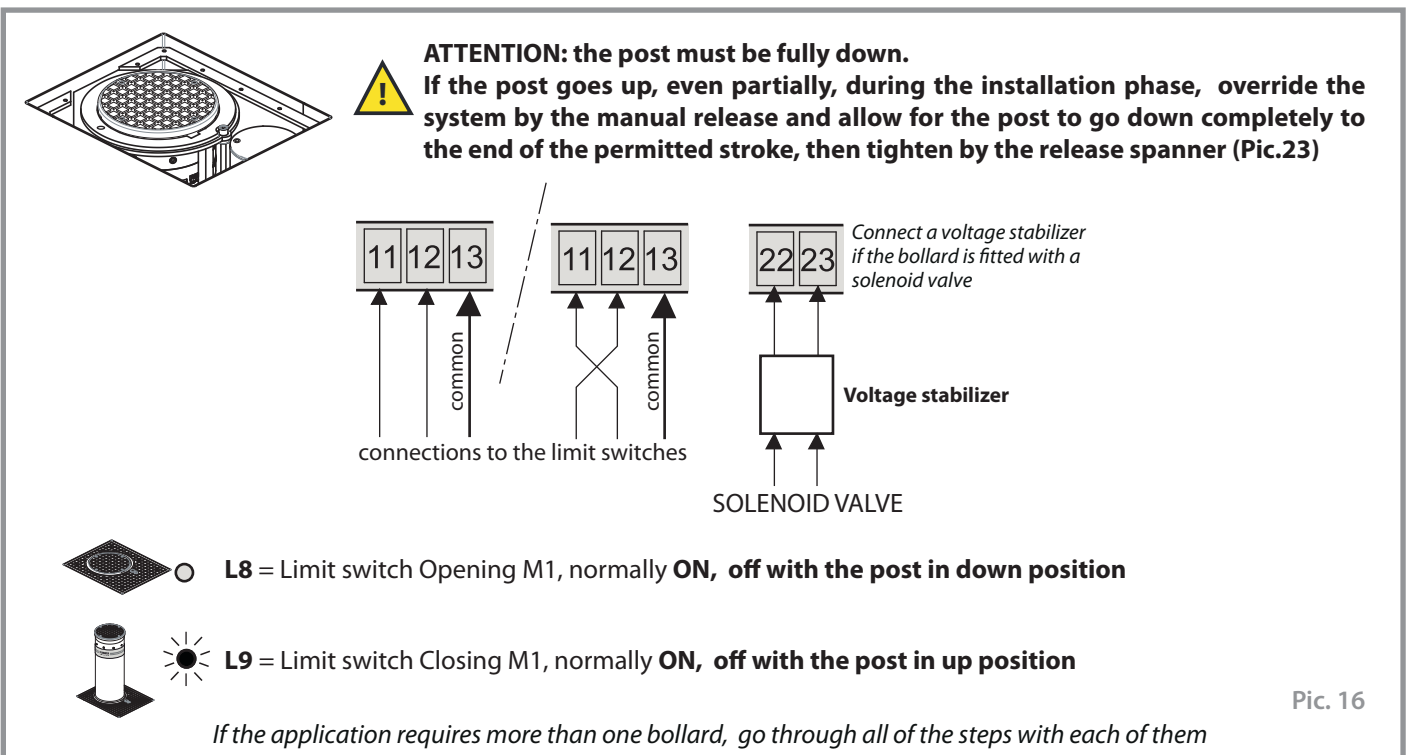

Pic. 16

(**) Once satisfied that voltage is properly supplied to the system, and provided that the LEDs of the limit switches are correctly switched (post down L8 is OFF), by the first pulse the post should rise, if not swap the motor live connections (in Elpro S40) after voltage supply to the system has been switched off.

English



ATTENTION: A 30µF capacitor is pre-wired inside the junction box. For the Talos option 4mm thickness (FE 360 steel and Inox/stainless steel) do NOT connect any more capacitors to the terminals A and B of the Elpro S40 controller unless required to achieve a good performance of the bollard. For the Talos option 12mm thickness a 20µF capacitor is required to be added to the terminals A and B of Elpro S40

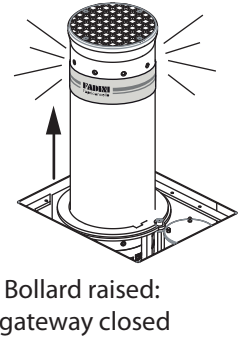
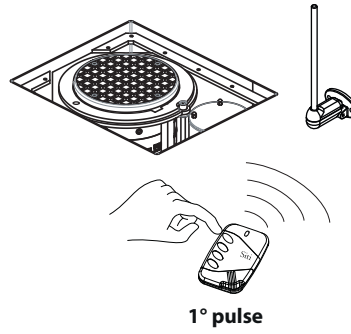
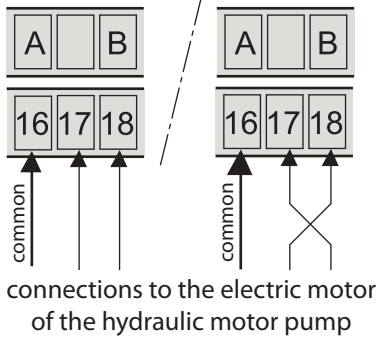

If the application requires more than one bollard, go through all of the steps with each

Pic. 17

FIXING THE COVER PLATES OF THE BOLLARD

The cover plate is to firmly rest all over the surface and closely adhere to the circular flange around the post



NOTE WELL: BOLLARD AND COVER PLATE ARE TO BE PERFECTLY CENTERED, SO THAT THE GAP BETWEEN BOLLARD AND COVER PLATE HOLE IS EQUALLY SPACED ALL AROUND

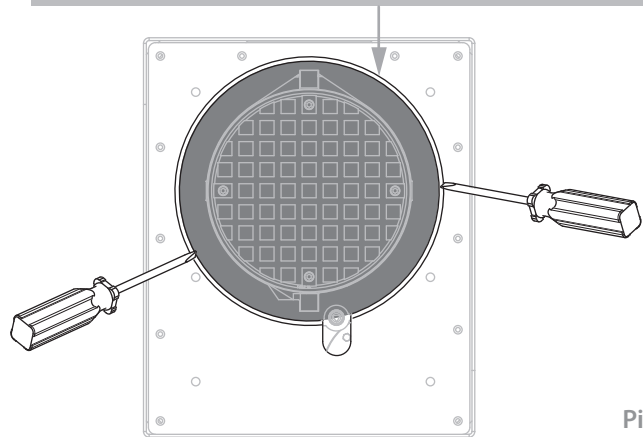
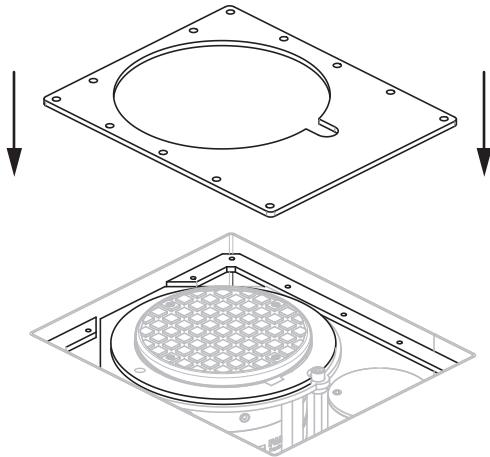

Pic. 18

M10

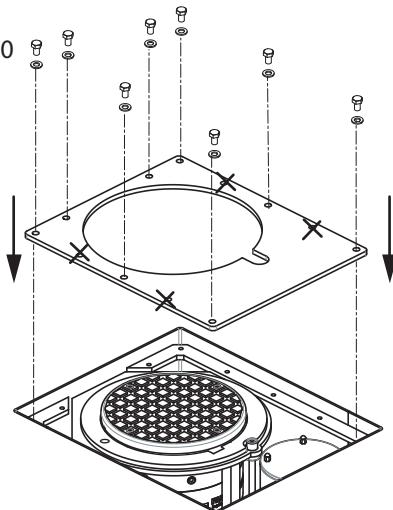

NOTE WELL: IT IS RECOMMENDED THAT ALL OF THE FIXING SCREWS BE GREASED

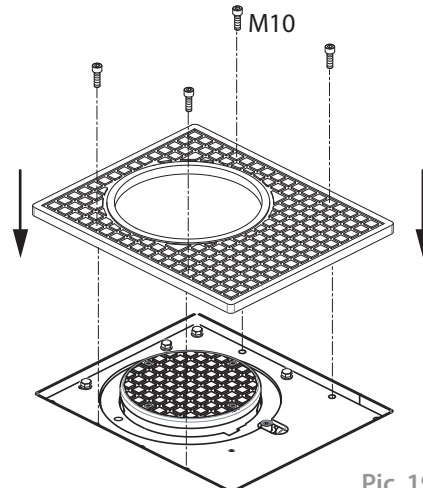

Pic. 19

BOLLARD WITH SOLENOID VALVE (OPTIONAL ACCESSORY)

With the version of the bollard where a solenoid valve (24Vdc) is fitted, in case of power failure, the post is allowed to lower by itself flat to ground level.

If a solenoid valve is fitted, a voltage stabilizer is also required: this accessory is absolutely necessary and is to be fitted between the solenoid valve power output (terminals 22 and 23) and the solenoid valve.

Be reminded that only one stabilizer can be fitted to each solenoid valve



ATTENTION: WITH POST THICKNESS 4mm, BOTH FE STEEL AND INOX/STAINLESS STEEL, IT IS REQUIRED THAT THE POST BE ASSISTED TO REACH THE FULLY FLAT DOWN POSITION

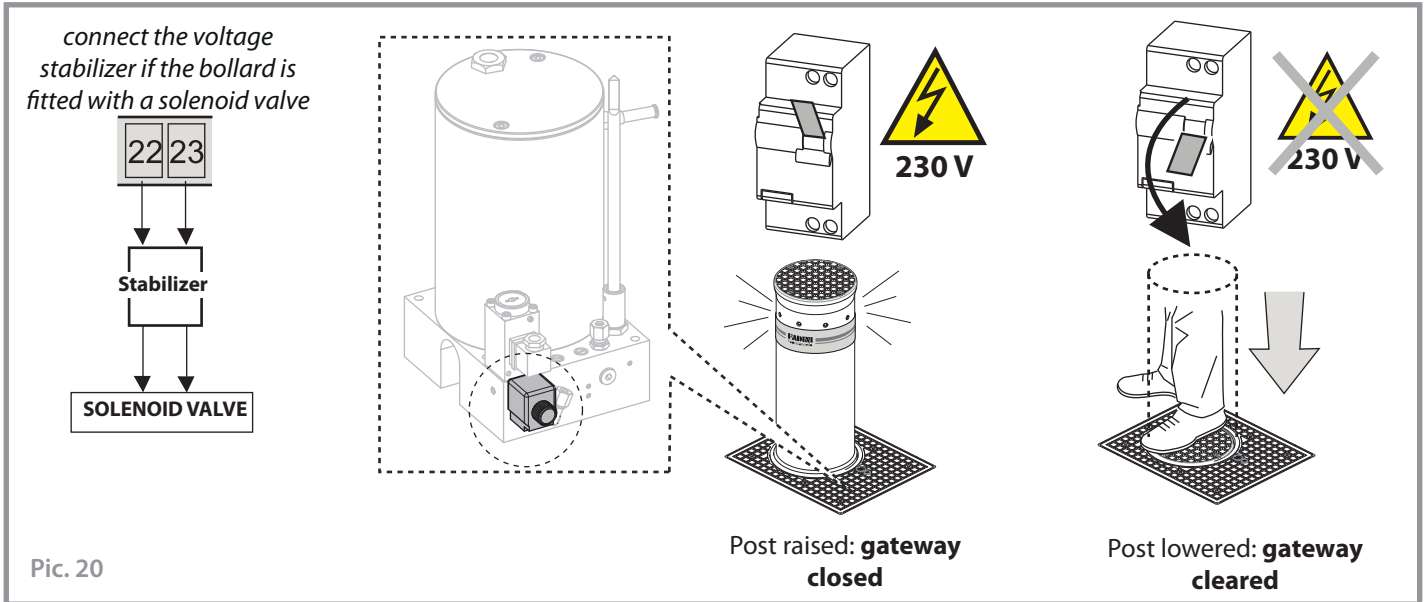

BOLLARD FITTED WITH PRESSURE SWITCH ie. PRESENCE DETECTOR (OPTIONAL ITEM)

In the version where the bollard is fitted with a pressure switch, any obstacle standing on the post prevents it from rising, or should the post be in the rising phase it reverses movement and lowers completely flat to ground level.

The pressure switch is factory preset for a minimum weight of about 15Kg.

A new setting is possible to be made though, in compliance with the installation requirements.

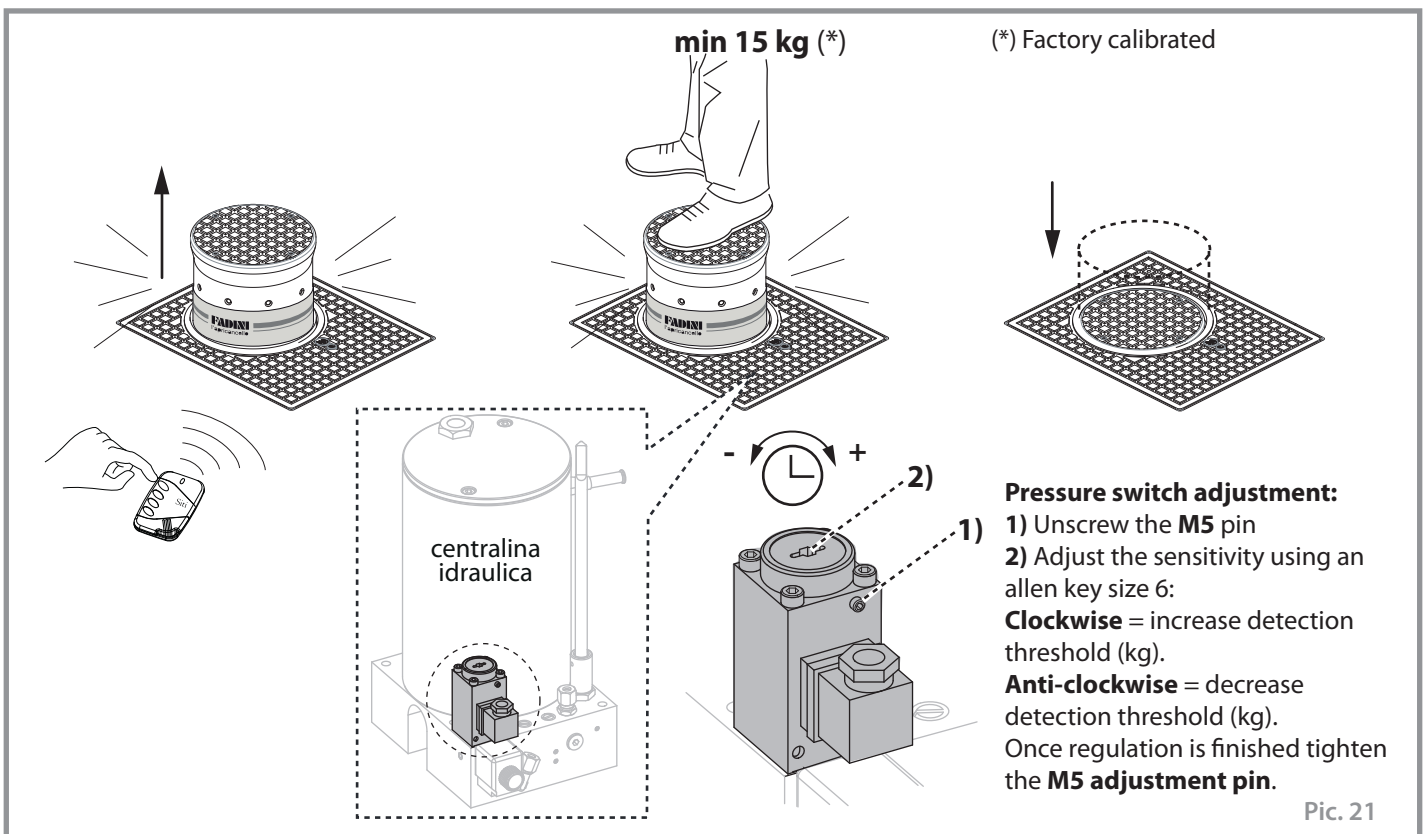

MANUAL RELEASE AND LOWERING OPERATIONS

The bollard has an override system allowing for the manual lowering of the post. A spanner with a universal triangle socket at the end is supplied with the equipment to release the unit and allow manual lowering.

ATTENTION: Once the post has been manually lowered, rising can be made possible only by powering the system and pulsing it to rise.

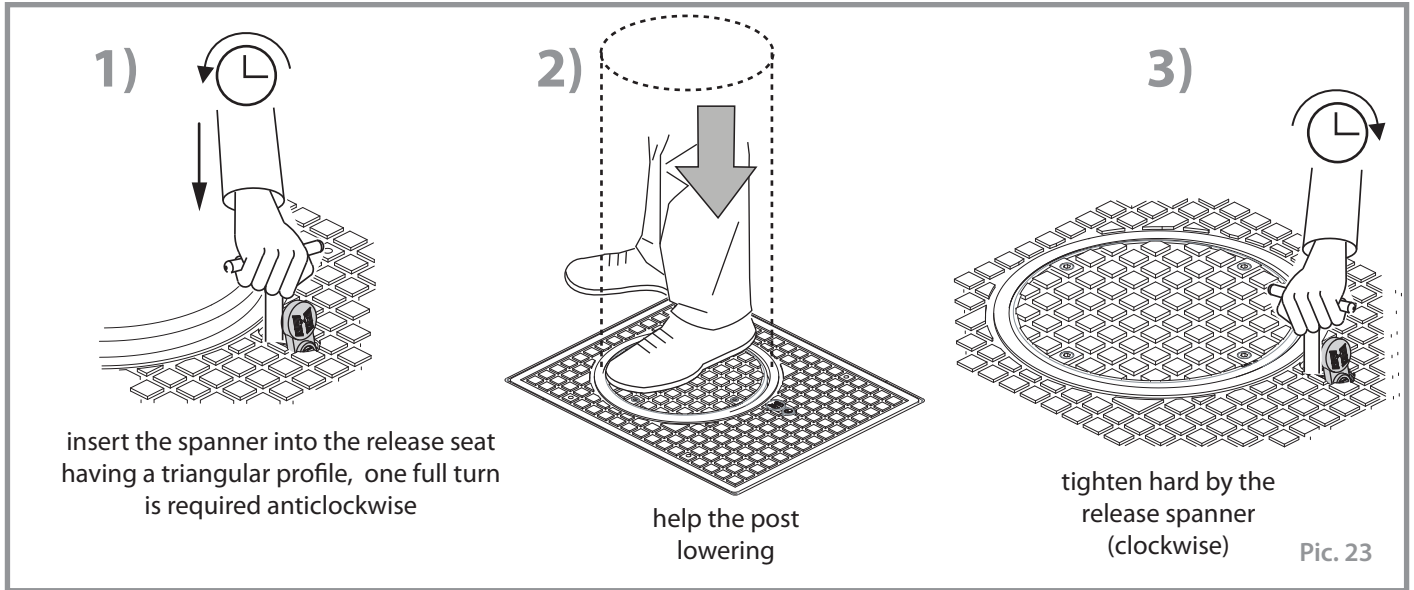
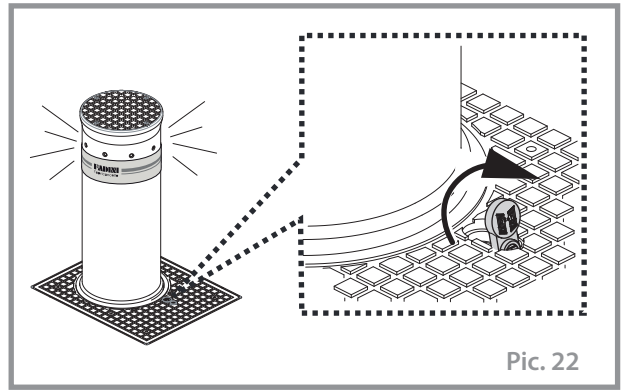

English

MAINTENANCE RECORD
hand over to the end user of the installation



Installation address:		Maintainer:	Date:	
Installation type:		Operator model:	Quantity of models installed:	
Sliding gate	<input type="checkbox"/>	Folding door	<input type="checkbox"/>	
Swinging gate	<input type="checkbox"/>	Road barrier	<input type="checkbox"/>	
Over-head door	<input type="checkbox"/>	Bollard	<input checked="" type="checkbox"/>	
Lateral folding door	<input type="checkbox"/>	<input type="checkbox"/>	
		Dimensions per gate leaf:		
		Weight per gate leaf:	Installation date:	

NOTE WELL: this document must record any ordinary and extraordinary services including installation, maintenance, repairs and replacements to be made only by using Fadini original spare parts. This document, for the data included in it, must be made available to authorized inspectors/officers, and a copy of it must be handed over the end user/s.

The installer/maintainer are liable for the functionalities and safety features of the installation only if maintenance is carried on by qualified technical people appointed by themselves and agreed upon with the end user/s.

N°	Service date	Service description	Technical maintainer	End user/s
1				
2				
3				
4				
5				
6				

Stamp and signature
installation technician/maintainer

Signed for acceptance
end user
buyer

give to the end-user of the installation



GENERAL WARNINGS FOR PEOPLE SAFETY

INTRODUCTION

This operator is designed for a specific scope of applications as indicated in this manual, including safety, control and signaling accessories as minimum required with **FADINI** equipment. □ Any applications not explicitly included in this manual may cause operation problems or damages to properties and people. □ Meccanica Fadini snc is not liable for damages caused by the incorrect use of the equipment, or for applications not included in this manual or for malfunctioning resulting from the use of materials or accessories not recommended by the manufacturer. □ The manufacturer reserves the right to make changes to its products without prior notice. □ All that is not explicitly indicated in this manual is to be considered not allowed.

BEFORE INSTALLATION

Before commencing operator installation assess the suitability of the access, its general condition and the structure. □ Make sure that there is no risk of impact, crushing, shearing, conveying, cutting, entangling and lifting situations, which may prejudice people safety. □ Do not install near any source of heat and avoid contacts with flammable substances. □ Keep all the accessories able to turn on the operator (transmitters, proximity readers, key-switches, etc) out of the reach of the children. □ Transit through the access only with stationary operator. □ Do not allow children and/or people to stand in the proximity of a working operator. □ To ensure safety in the whole movement area of a gate it is advisable to install photocells, sensitive edges, magnetic loops and detectors. □ Use yellow-black strips or proper signals to identify dangerous spots. □ Before cleaning and maintenance operations, disconnect the appliance from the mains by switching off the master switch. □ If removing the actuator, do not cut the electric wires, but disconnect them from the terminal box by loosening the screws inside the junction box.

INSTALLATION

All installation operations must be performed by a qualified technician, in observance of the Machinery Directive 2006/42/CE and safety regulations EN 12453 - EN 12445. □ Verify the presence of a thermal-magnetic circuit breaker 0,03 A - 230 V - 50 Hz upstream the installation. □ Use appropriate objects to test the correct functionality of the safety accessories, such as photocells, sensitive edges, etc. □ Carry out a risk analysis by means of appropriate instruments measuring the crushing and impact force of the main opening and closing edge in compliance with EN 12445. □ Identify the appropriate solution necessary to eliminate and reduce such risks. □ In case where the gate to automate is equipped with a pedestrian entrance, it is appropriate to prepare the system in such a way to prohibit the operation of the engine when the pedestrian entrance is used. □ Apply safety nameplates with CE marking on the gate warning about the presence of an automated installation. □ The installer must inform and instruct the end user about the proper use of the system by releasing him a technical dossier, including: layout and components of the installation, risk analysis, verification of safety accessories, verification of impact forces and reporting of residual risks.

INFORMATION FOR END-USERS

The end-user is required to read carefully and to receive information concerning only the operation of the installation so that he becomes himself responsible for the correct use of it. □ The end-user shall establish a written maintenance contract with the installer/maintenance technician (on -call). □ Any maintenance operation must be done by qualified technicians. □ Keep these instructions carefully.

WARNINGS FOR THE CORRECT OPERATION OF THE INSTALLATION

For optimum performance of system over time according to safety regulations, it is necessary to perform proper maintenance and monitoring of the entire installation: the automation, the electronic equipment and the cables connected to these. □ The entire installation must be carried out by qualified technical personnel, filling in the Maintenance Manual indicated in the Safety Regulation Book (to be requested or downloaded from the site www.fadini.net/supporto/downloads).

□ Operator: maintenance inspection at least every 6 months, while for the electronic equipment and safety systems an inspection at least once every month is required. □ The manufacturer, Meccanica Fadini snc, is not responsible for non-observance of good installation practice and incorrect maintenance of the installation.

DISPOSAL OF MATERIAL

Dispose properly of the packaging materials such as cardboard, nylon, polystyrene etc. through specializing companies (after verification of the regulations in force at the place of installation in the field of waste disposal). Disposal of electrical and electronic materials: to remove and dispose through specializing companies, as per Directive 2003/108/CE.

Disposal of substances hazardous for the environment is prohibited.

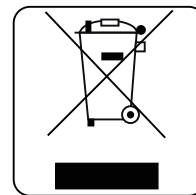

TECHNICAL DATA

BOLLARD

Post diameter	Ø 275 mm	
Post thickness	4 and 12 mm	
Post height range	500, 600, 700 and 800 mm	
Finishing of the Fe post	Polyester powder coating	
Piston diameter	30 mm	
Shaft diameter	16 mm	
Piston stroke range	510, 610, 710 and 810 mm	
Factory set thrust power	61 daN (61 kg)	
Frequency of use	intensive	
LED / beeper power adaptor	in: 230 V - 50 Hz out: 12 Vdc 600mA	
LED lights	12 Vdc	
Post material	"FE 360" steel AISI 304 inox SS steel	
	standard	HRC
Impact resistance (thick. 4)	52.000 J	70.000 J
Crash resistance (thick. 4)	320.000 J	420.000 J
Impact resistance (thick. 12)	60.000 J	90.000 J
Crash resistance (thick. 12)	450.000 J	550.000 J
Maximum static load	20.000 kg	20.000 kg

ELECTRIC MOTOR

Absorbed power	1.100 W
Power supply	230 V
Frequency	50 Hz
Rated current	1,8 ÷ 3,5 A
Maximum current	5 A
Intermittent service	S3
Capacitor	30µF

HYDRAULIC MOTOR PUMP

Pump type	P20
Working pressure	20 MPa (20 bar)
Working temperature	- 20 °C + 80 °C
Oil type	Oil Fadini - code 708L
Oil reservoir	3 liters
Protection grade	IP 67 without pressure switch and solenoid valve IP 65 with pressure switch and solenoid valve

Individual weight of the bollards

Model	stroke	post thickness	weight	time		Model	stroke	post thickness	weight	time	
				rising	lowering					rising	lowering
TALOS 9450	500	4	196 kg	2,14 s	2,00 s	TALOS 9651	500	12	234 kg	2,80 s	2,14 s
TALOS 9450/HRC	500	4	202 kg	2,14 s	2,00 s	TALOS 9651/HRC	500	12	252 kg	2,80 s	2,14 s
TALOS 9460	600	4		2,57 s	2,40 s	TALOS 9661	600	12		3,40 s	2,57 s
TALOS 9460/HRC	600	4		2,57 s	2,40 s	TALOS 9661/HRC	600	12		3,40 s	2,57 s
TALOS 9470	700	4	218 kg	3,00 s	2,80 s	TALOS 9671	700	12	252 kg	4,00 s	3,00 s
TALOS 9470/HRC	700	4	234 kg	3,00 s	2,80 s	TALOS 9671/HRC	700	12	275 kg	4,00 s	3,00 s
TALOS 9480	800	4		3,42 s	3,20 s	TALOS 9681	800	12		4,50 s	3,42 s
TALOS 9480/HRC	800	4		3,42 s	3,20 s	TALOS 9681/HRC	800	12		4,50 s	3,42 s

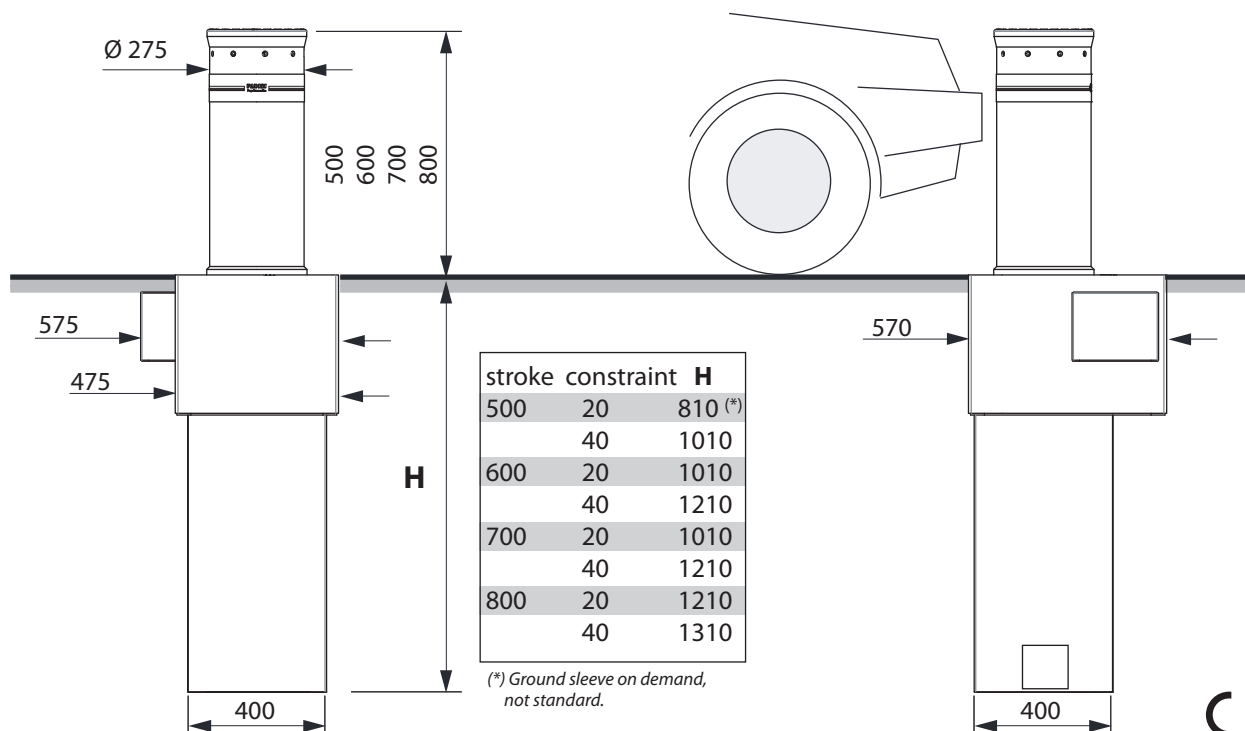

2002/95/CE Directive
Re. disposal of electric
and electronic waste
DISPOSE PROPERLY OF MATERIALS
ARMFUL TO THE ENVIRONMENT